

SCHEMA ELETTRICO / ELECTRIC DIAGRAM

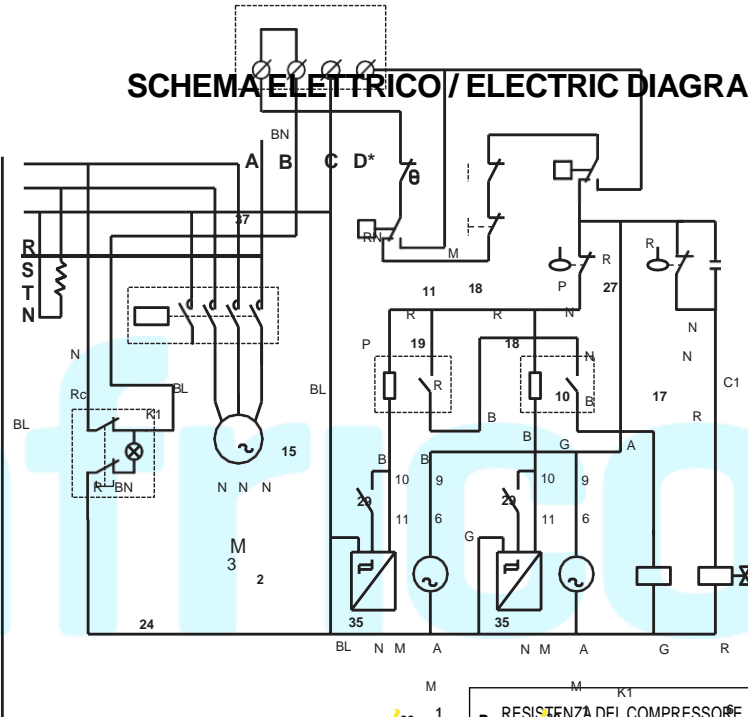
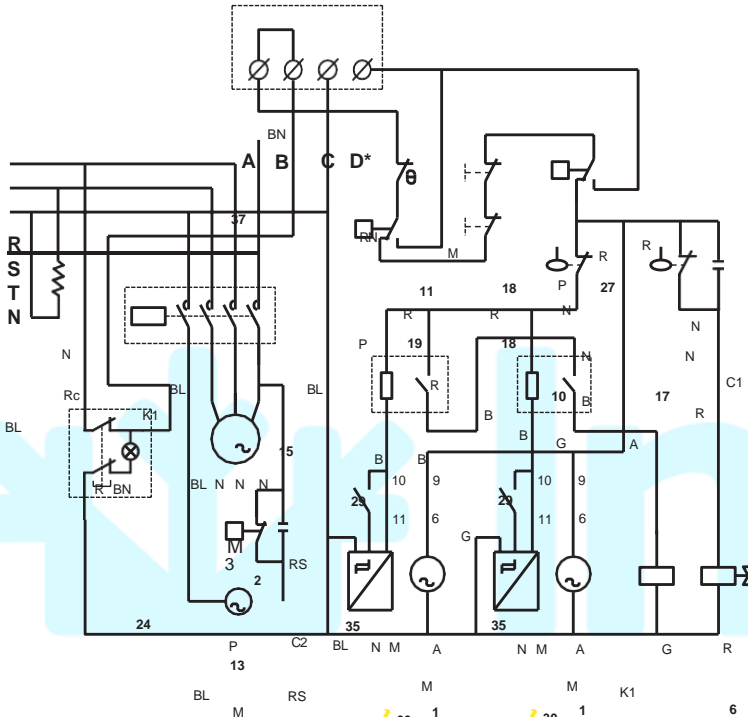

| | |
|---|---|
| 1. MOTORE DEL RIDUTTORE GEAR REDUCTION MOTOR | 13. PRESSOSTATO CONTROLLO CONDENSAZIONE CONDENSER CONTROL PRESSURE SWITCH |
| 2. COMPRESSORE COMPRESSOR | 15. TELERUTTORE CONTACTOR |
| 4. MOTOVENTILATORE FAN MOTOR | 17. MICRO CONTROLLO LIVELLO ACQUA BACINELLA BASIN WATER'S LEVEL MICRO SWITCH |
| 6. ELETTROVALVOLA INGRESSO ACQUA BACINELLA BASIN'S WATER INLET VALVE | 18. CONTROLLO CONTENITORE PIENO STORAGE BIN CONTROL |
| 10. MICRO CONTROLLO MANCANZA ACQUA BACINELLA BASIN'S WATER'S LACK MICRO SWITCH | 19. PRESSOSTATO DI SICUREZZA SAFETY PRESSURE SWITCH |
| 11. TERMOSTATO CONTENITORE BIN THERMOSTAT | 24. INTERRUOTTORE LUMINOSO SWITCH ON - OFF (GREEN LIGHT) |

| |
|---|
| 27. PRESSOSTATO DI SICUREZZA BASSA PRESSIONE SAFETY PRESSURE SWITCH FOR LOW PRESSURE |
| 29. RELE' RELAY |
| 30. SENSORE DI ROTAZIONE ROTATION SENSOR |
| 35. BY-PASS ESCLUSIONE ATTESA WAITING CUTTING OUT BYPASS DA UTILIZZARE SOLO DAL MANUTENTORE TO BE USED BY THE MAINTENANCE PERSONNEL ONLY |
| 37. MORSETTIERA PER COLLEGAMENTO A SCATOLA ELETTTRICA REMOTA O DRB 500 TERMINAL BLOCK FOR CONNECTION TO REMOTE PANEL OR DRB 500 |

Rc RESISTENZA DEL COMPRESSORE
BL COMPRESSOR RESISTANCE

A = ARANCIO / ORANGE
B = BIANCO / WHITE
BL = BLU / BLUE
G = GRIGIO / GREY
M = MARRONE / BROWN
N = NERO / BLACK
R = ROSSO / RED
RS = ROSA / PINK
BN = BIANCO-NERO / WHITE-BLACK
RN = ROSSO-NERO / RED-BLACK

* NON UTILIZZARE PER COLLEGAMENTO A DRB 500 / NOT BE USED FOR CONNECTION TO DRB 500

Cod. 24584 - Rev. 05

